

872 XLS LM

Automatic Bag Closing Machine

The Kwik Lok 872XLS LM Automatic Bag Closing Machine enables the packager to close and label bagged packages with one machine at speeds up to 105 per minute. The system will close a wide range of product size variations and features an operating panel for speed control, a shift counter, lifetime counter and manual cycle button.

STANDARD FEATURES

- Brushless AC 3 phase induction motor which reduces inspection and maintenance costs by eliminating brush and armature wear
- Adjustable idler pulley increases the belt wrap by 50% on the roll pulley reducing belt tooth skipping under high-load conditions and reduces clutch wear
- Bag jam detection, bag jam cleanse mode and bag jam alarm relay circuit
- Actuating lever with an electronic sensor that determines width of the bag and then actuates the bag closing cycle allowing closing of a wide range of widths without adjustment
- Spring release pick feed prevents closure jamming if a package or its contents are improperly delivered to the closing head

TYPICAL APPLICATIONS

- Bakery products

SPECIFICATIONS

Height	42"
Width	11.75"
Length	24.5"



Kwik Lok®

KWIKER IS BETTER



Kwik Lok[®]

872 XLS LM Automatic Bag Closing Machine

CLOSURE

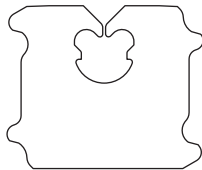

J-NRP **.030"**
K-NRP **.045"**

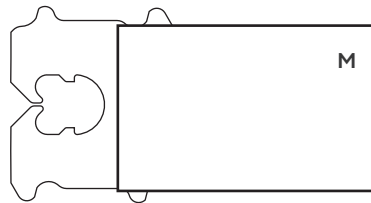

CLOSURE-LABELS

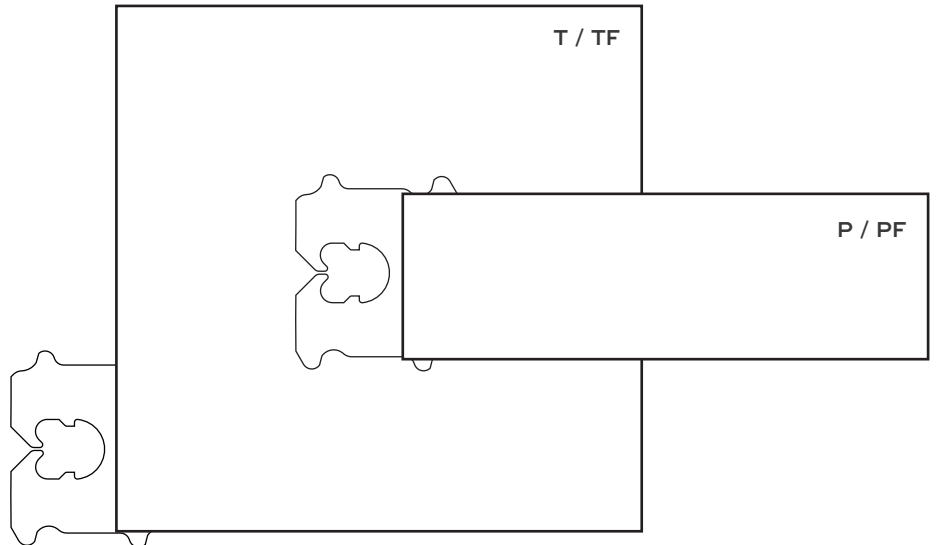
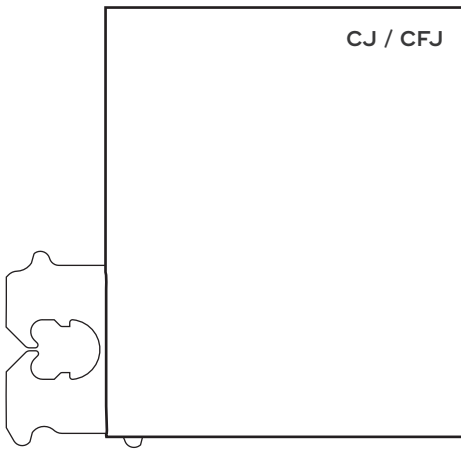

Various plastic thicknesses (in red) handle a wide range of package types, weights and sizes.

Closures can be printed with price, date and/or code information.

Available colors vary with plastic thickness: .030" – 7 colors .045" – 3 colors

Our line includes a full range of printers, stands, conveyors and bag tensioners compatible with the 872 Automatic Bag Closing Machine.

PRINTERS

883 P
897 A
904 A
905 A
1011 E

STANDS

902
Z8025

CONVEYORS

1083 FB
1083 T

BAG TENSIONERS

1082 L8